



LUMINAIRE INTEGRATION

MOUNTING CONSTRUCTION FOR PROCESSING TWO HALF SPHERES BETWEEN A PANEL

STEP 1

- Divide the two half spheres by unscrewing the inbus bolt at the centre of the sphere and unplugging the connection.
- The half spheres can then be remounted on the top and bottom side of a panel.

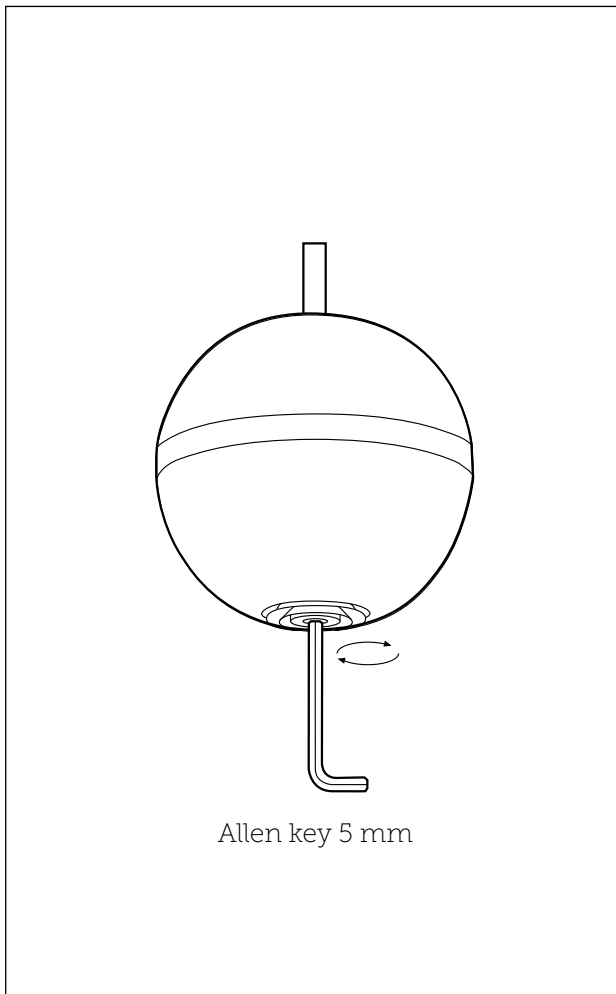

STEP 2

- The panel needs to have a minimal thickness of **6.5 mm** and the hole in the panel needs to be approx. **133.5 mm**. Pay attention to the positioning pins and the connection between the half spheres, when remounting the sphere.

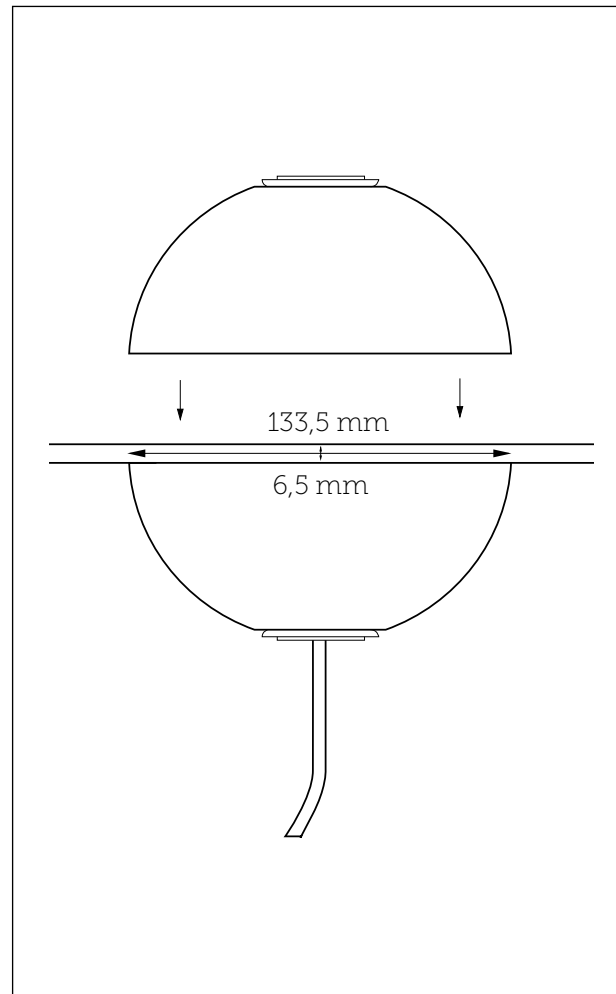

STEP 3

- When the LED-Sphere is carrying the luminaire, and make sure the maximum weight of the luminaire is 5 kg.

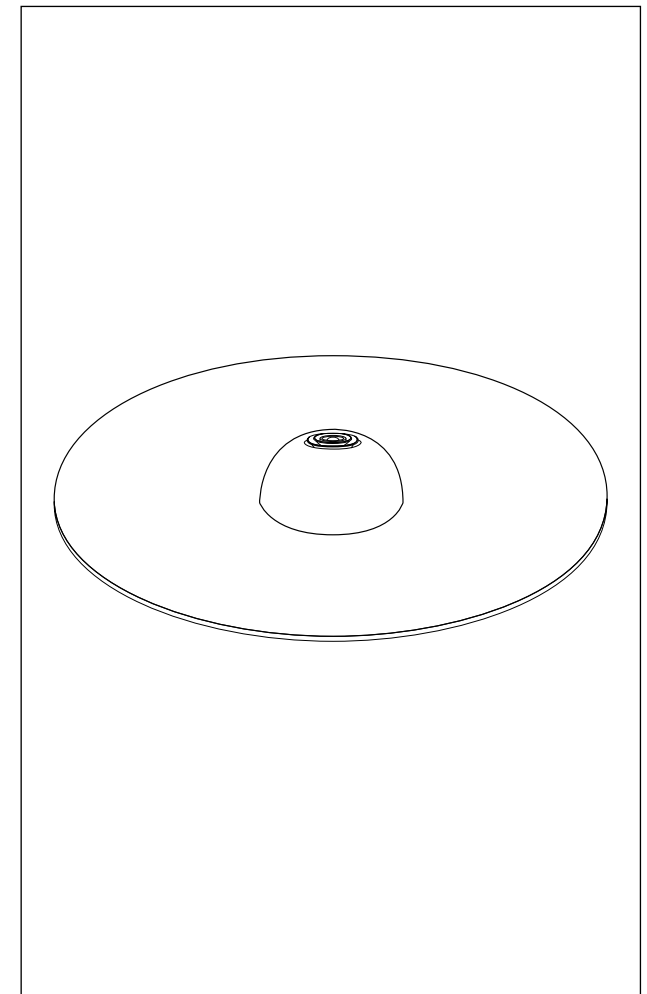



COMPATIBILITY TABLE

MOUNTING CONSTRUCTION FOR LED-SPHERE

DRIVERS AND ENGINES

	EXTERNAL DRIVER				INTERNAL DRIVER	
	CASAMBI	DMX	DALI	0-10 VOLT	CASAMBI	DMX
GLARELESS SPOT SINGLE WHITE	X	X	X	X		
GLARELESS SPOT DUAL WHITE/ WARM DIMMING	X		X		X	X
GLARELESS SPOT DUAL WHITE / TUNABLE WHITE	X	X	X		X	X
GLARELESS SPOT RGB+W					X	X
LED-SPHERE BASIC DUAL WHITE/ DUAL WHITE					X	X
LED-SPHERE PREMIUM RGB+W/ DUAL WHITE					X	X
LED-SPHERE ULTIMATE RGB+W/ RGB+W					X	X
POWERLINE SINGLE WHITE	X				X	X
POWERLINE DUAL WHITE / WARM DIMMING					X	
POWERLINE DUAL WHITE/ TUNABLE WHITE					X	X
POWERLINE RGBW+W					X	X
OUTDOOR ENGINE					X	

MANUALS

WWW.DYDELL.COM

Want to know more about the wiring and connecting the engine to the driver? Scan the QR code below to go to the instruction page on our website. Is the QR code not working? Copy this link: <https://www.dydell.com/nl/video-instructies-handleidingen/> into your browser.

