



MOUNTING CONSTRUCTION

MOUNTING CONSTRUCTION FOR POWERLINE (PL25 & PL35)

STEP 1

- Screw the clips into the wall with **3x30 z1** screws. The amount of clips depends on the number of meters of powerline.

Note: The PL25 and PL35 use the same clip size.

STEP 2

- There should be 1 clip per half meter of powerline screwed in to the wall.

STEP 3

- Click the powerline into the clips which have been attached to the wall. There are two lines at the backside of the powerline that can be clicked into the clips.

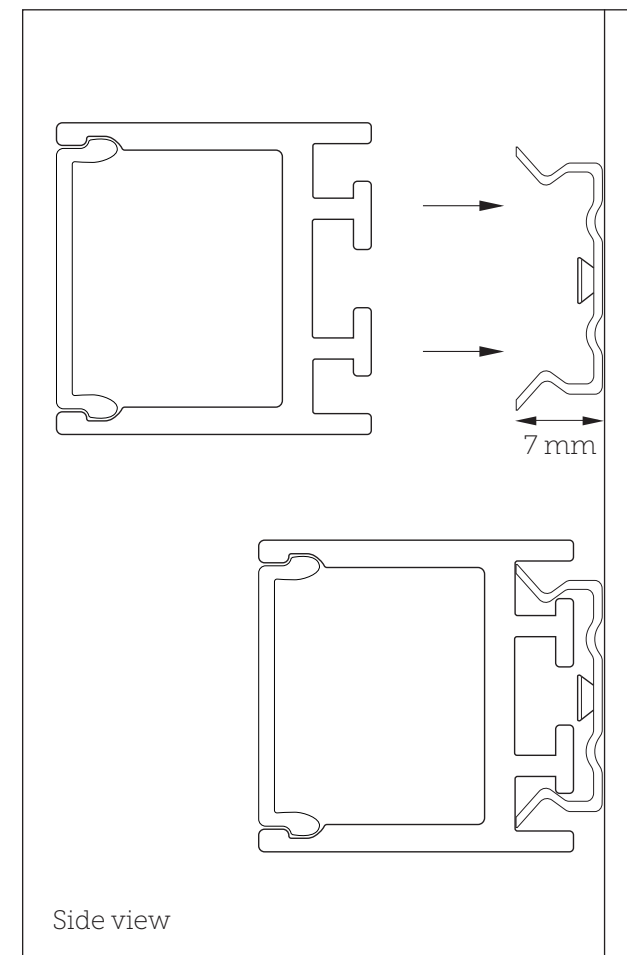
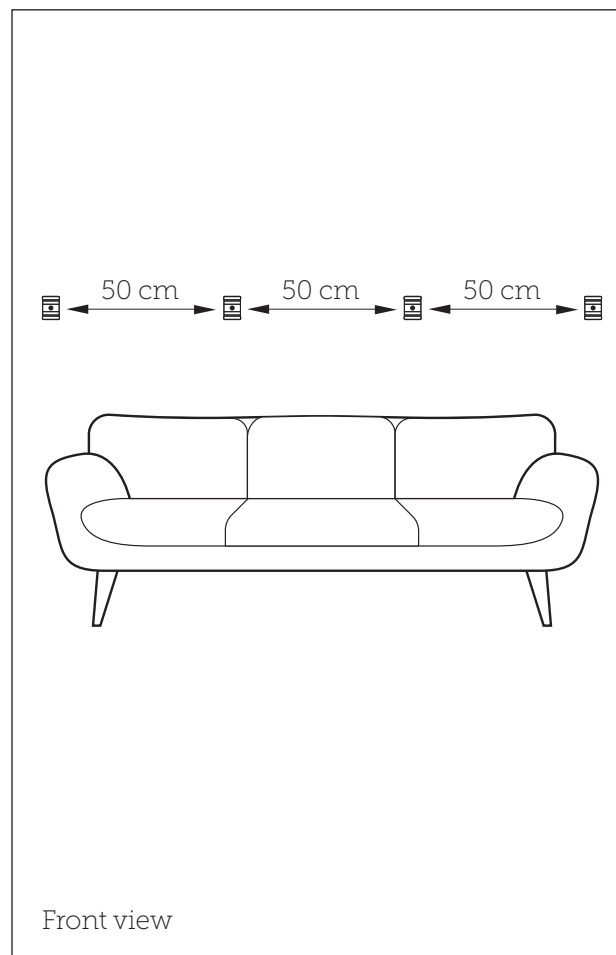
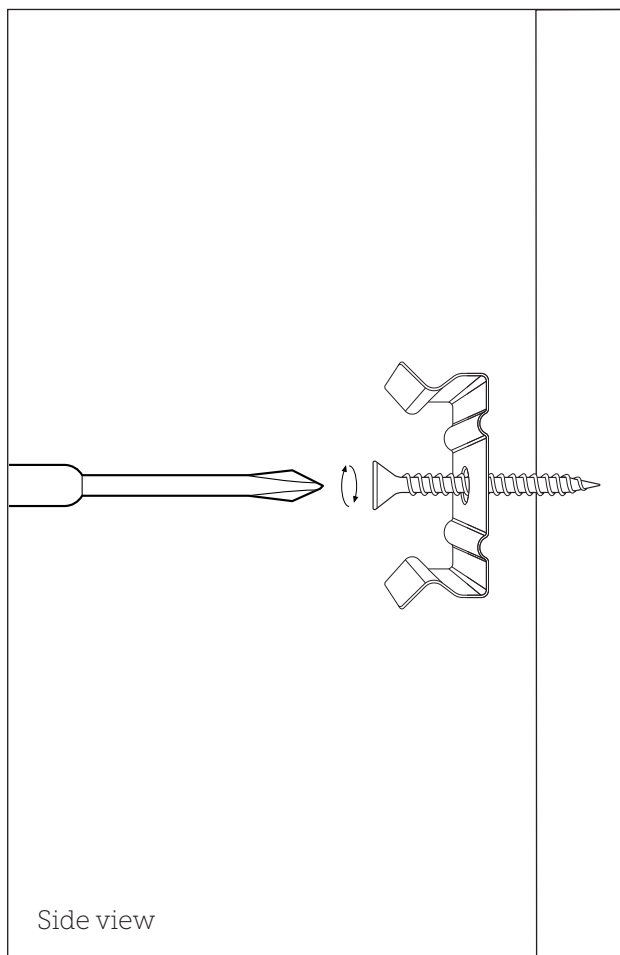



MOUNTING CONSTRUCTION

MOUNTING CONSTRUCTION FOR POWERLINE (PL25 & PL35)

STEP 3

- Put the strain relief on the wiring and tighten with a twisting motion.
- When the strain relief is secure, tighten once more with a flat head screw driver.

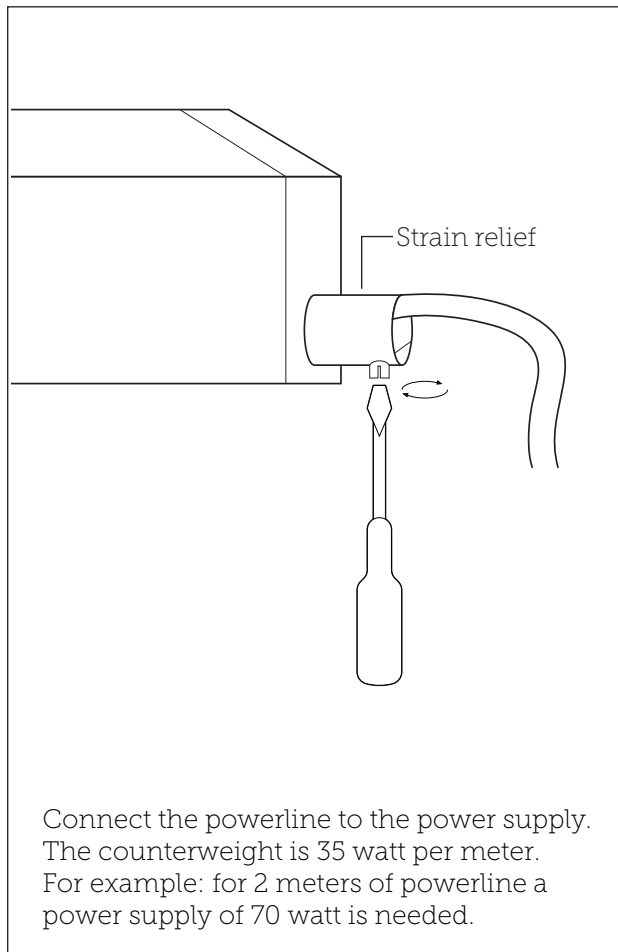



COMPATIBILITY TABLE

MOUNTING CONSTRUCTION FOR LED-SPHERE

DRIVERS AND ENGINES

	EXTERNAL DRIVER				INTERNAL DRIVER	
	CASAMBI	DMX	DALI	0-10 VOLT	CASAMBI	DMX
GLARELESS SPOT SINGLE WHITE	X	X	X	X		
GLARELESS SPOT DUAL WHITE/ WARM DIMMING	X		X		X	X
GLARELESS SPOT DUAL WHITE / TUNABLE WHITE	X	X	X		X	X
GLARELESS SPOT RGB+W					X	X
LED-SPHERE BASIC DUAL WHITE/ DUAL WHITE					X	X
LED-SPHERE PREMIUM RGB+W/ DUAL WHITE					X	X
LED-SPHERE ULTIMATE RGB+W/ RGB+W					X	X
POWERLINE SINGLE WHITE	X				X	X
POWERLINE DUAL WHITE / WARM DIMMING					X	
POWERLINE DUAL WHITE/ TUNABLE WHITE					X	X
POWERLINE RGBW+W					X	X
OUTDOOR ENGINE					X	

MANUALS

WWW.DYDELL.COM

Want to know more about the wiring and connecting the engine to the driver? Scan the QR code below to go to the instruction page on our website. Is the QR code not working? Copy this link: <https://www.dydeLL.com/nl/video-instructies-handleidingen/> into your browser.

